

Holo

# Holo

Kenneth Jensen  
Head of Operations  
[keje@letsholo.com](mailto:keje@letsholo.com)

CPH, December 11th, 2020



Holo

# Real-world operations, technology, and learnings



# Agenda

- 1 Introduction to Holo and our ambitions**
- 2 Operations overview
- 3 Tools in use
- 4 Future operations

# Holo

Company	Geographies	Key role today	Employees	# projects*
 holo		Pure autonomous shared mobility deployment enabler and operator	55	7
 Forus   PRT		Pure autonomous shared mobility operator	3	1
 KEOLIS		Traditional public transport operator	10	3
 Nobina		Traditional public transport operator	5	1
 POSTBUS		Traditional public transport	7	1
 Sales-Lentz <small>moving people</small>		Traditional public transport operator	10	1
 BVG		Traditional public transport operator	5	1
 stpg		Traditional public transport operator	10	1

Largest dedicated autonomous shared mobility operator in Europe and holds a central position for scaling the industry

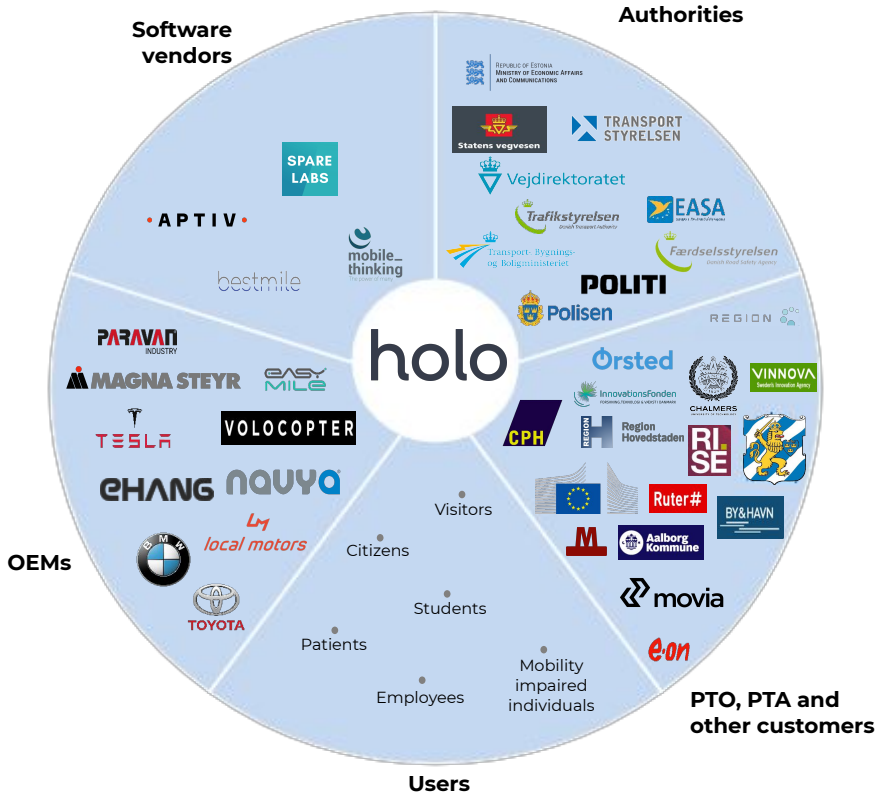

Largest dedicated autonomous shared mobility operator in Europe and holds a central position for scaling the industry

## Introduction

Based in Copenhagen, Denmark.

Founded in October 2016 by Semler Group, Scandinavia's largest automotive distributor.



**Semler Group** is a **104 year old** family-owned company that imports, sells and services VAG vehicles

Semler Group is operating in 8 countries:  
**Denmark, Sweden, Norway, Iceland, Finland, Lithuania, Estonia, Latvia**

**Holo** is a 100% owned company in the group, but **operates independently**

Holo was founded as a **response to the emergence of autonomous vehicles.**

# Mobility is changing...

Environment > Climate Change  
**Norway to 'completely ban petrol powered cars by 2025'**  
'What an amazingly awesome country', Elo

**Klimapanel: Bilerne skal presses ud af København, hvis klimamål skal indfries**

Selling Vehicles



10.11.18

**The off**  
As the need to reduce carbon emissions has pushed itself on a path to ban cars from

Starting in 2019, the Norwegian capital will restrict the use of vehicles in its city center, following a global trend to make popular tourist destinations more car-free and more pedestrian-friendly.

Selling Trips, Data, Know How

**Sådan kommer bilerne ud af Middelalderbyen**

**Privatbilen er på retur i de rigeste lande**

**Trafik løber løbsk: CO2-udslippet fra verdens transport stiger med 60 procent**



**of the Driver's**  
...ages are getting them, and it's not quite clear



Foto: Phil McCartney/AP WireImage

# Agenda

- 1 Introduction to Holo and our ambitions
- 2 Operations overview**
- 3 Tools in use
- 4 Future operations



# Extensive and unique operational experience

Being planned

In operation

Completed



**Oslo - Ski**

Ground vehicles



**Oslo - Ormøya**

Ground vehicles



**Gothenburg - Chalmers University**

Ground vehicles



**Odense, university hospital**

Air drone



**Aalborg - Aalborg East**

Ground vehicles



**Gothenburg - Lindholmen phase 1**

Ground vehicles



**Æro**

Air drone



**Copenhagen - Nordhavn**

Ground vehicles



**Køge - SUH Køge Hospital (indoors)**

Ground vehicle



**Svendborg**

Air drone



**Helsinki - Aurinkolahti**

Ground vehicle



**Slagelse**

Ground vehicle



**Tallinn - Sohjoa Baltic**

Ground vehicle



**Oslo - Akershusstranda**

Ground vehicle



**Oslo - Kongens Gate**

Ground vehicles

# Data background

## DISTANCE IN TOTAL PER TIME

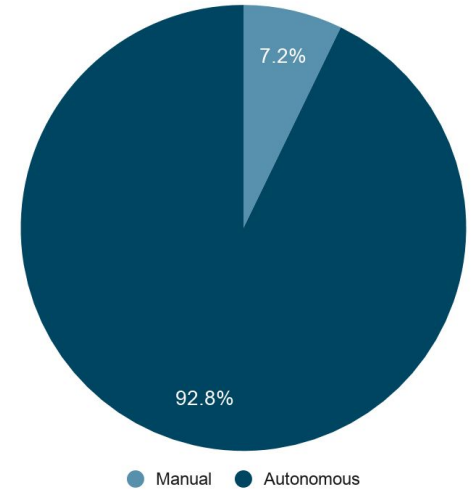
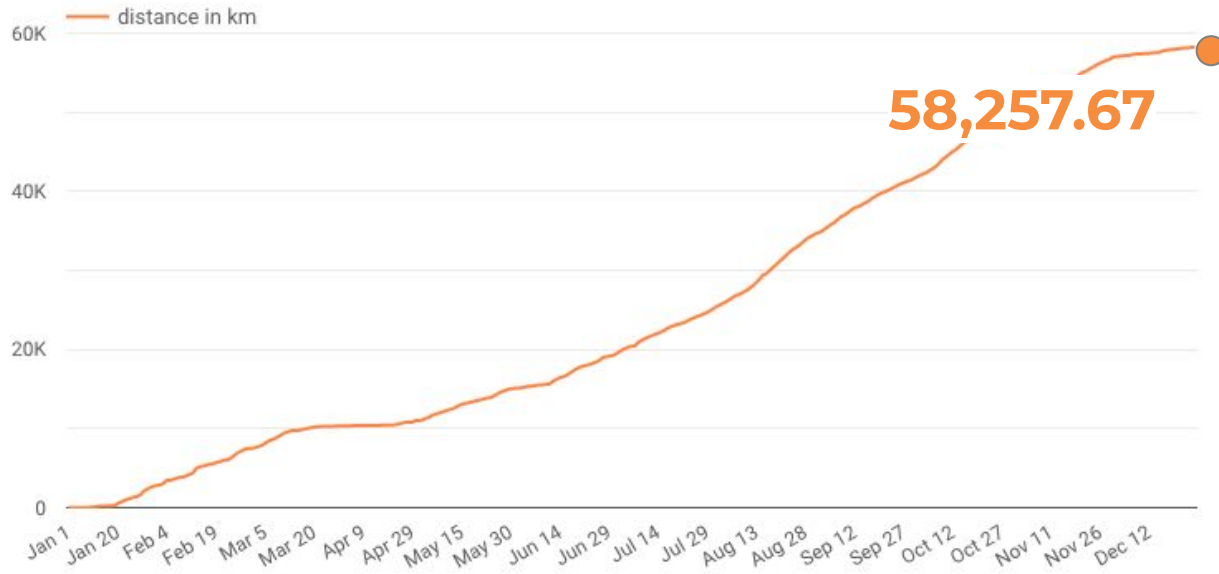

Passengers in total: 52k PAX



# Agenda

- 1 Introduction to Holo and our ambitions
- 2 Operations overview
- 3 Tools in use**
- 4 Future Operations

# Fleet architecture

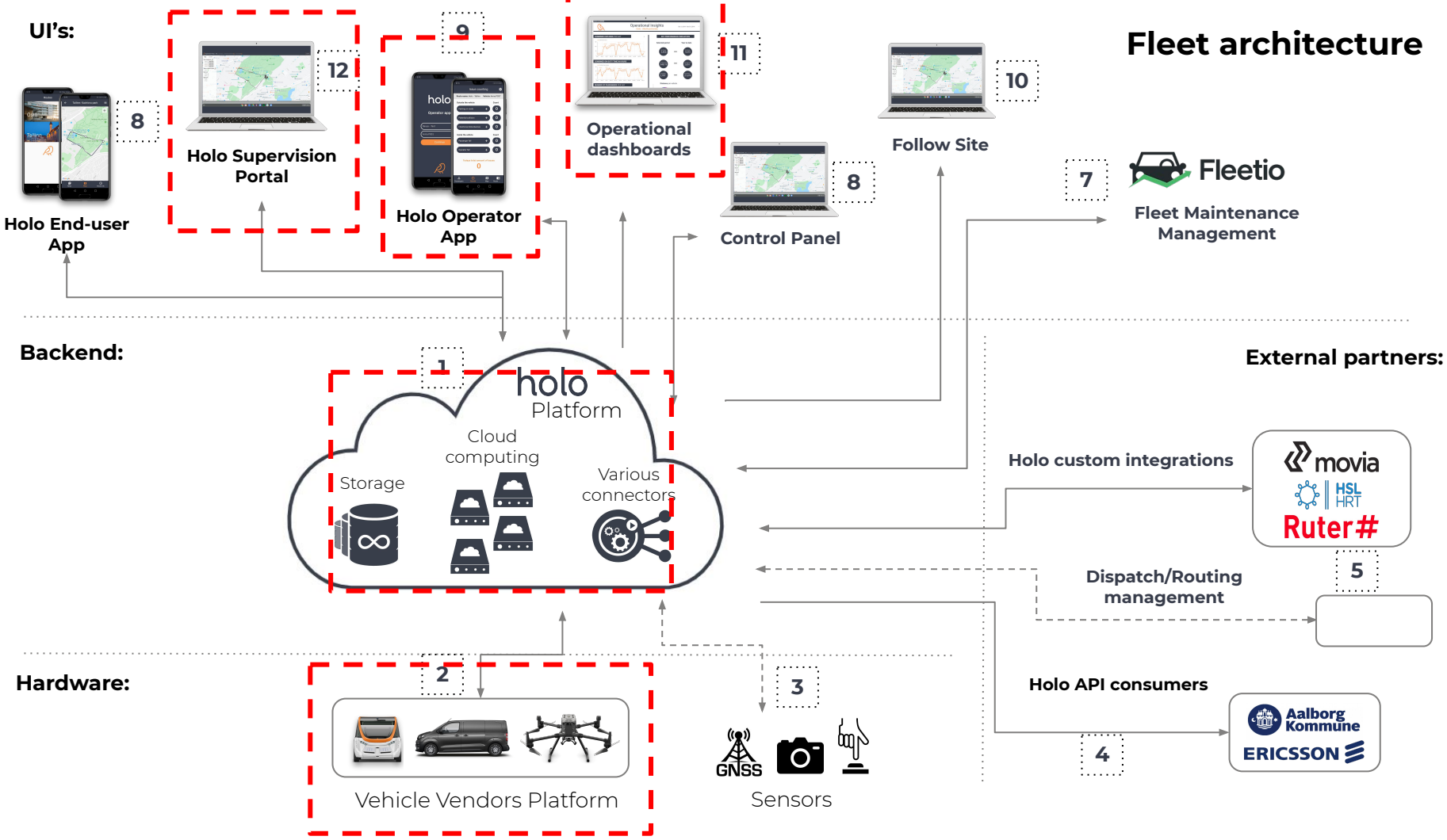

# Vehicle platform

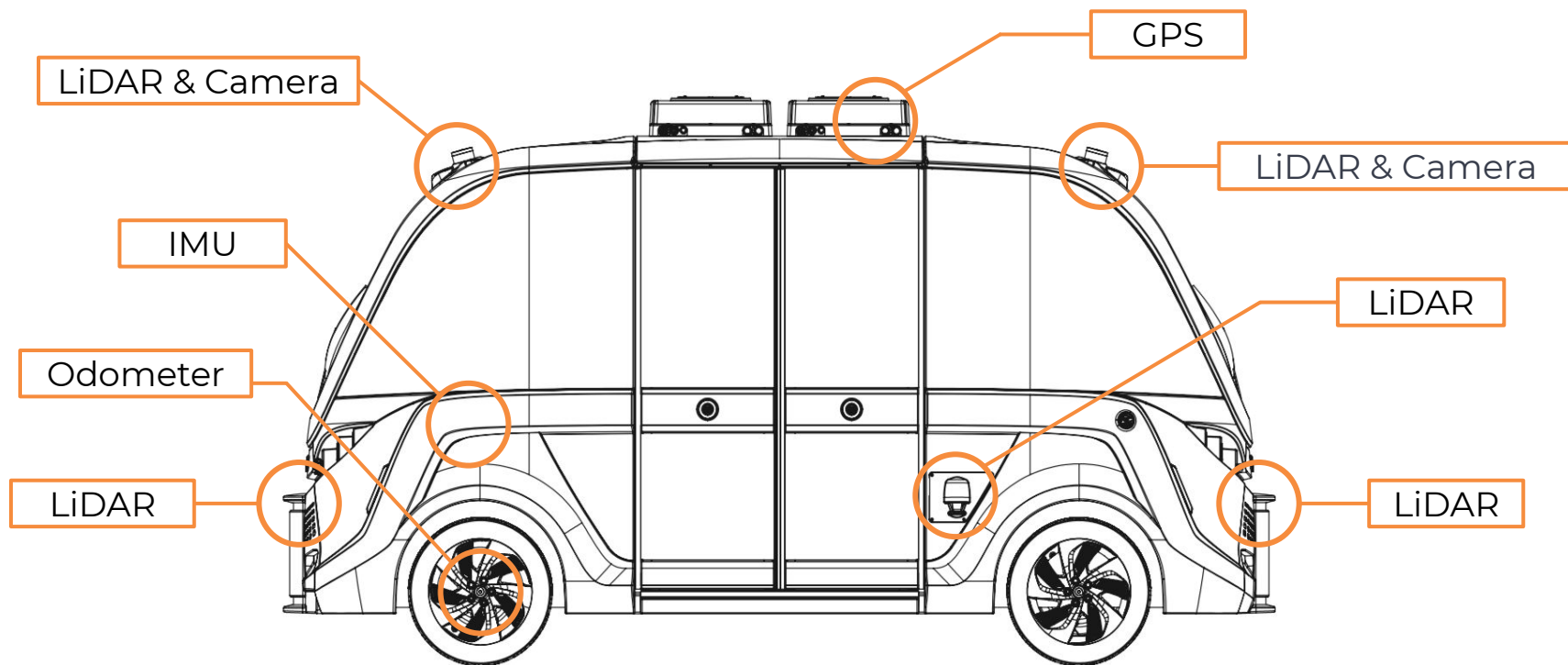

# Qualitative reporting

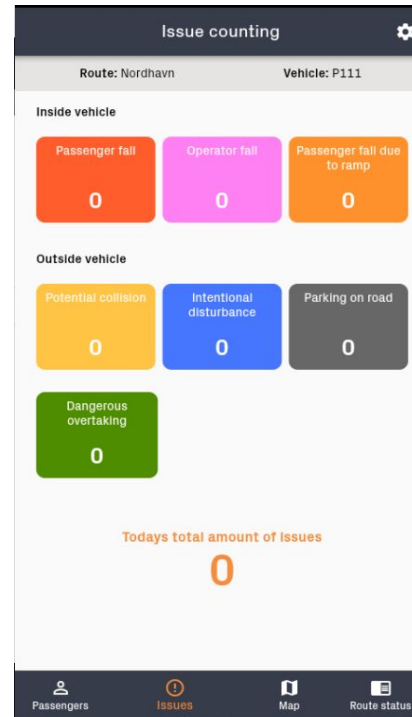
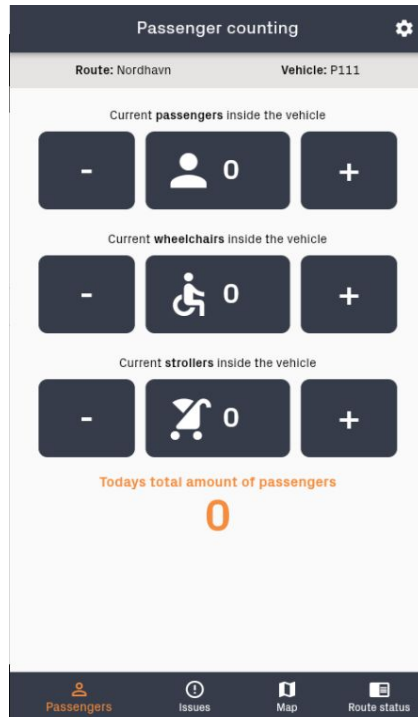

# Dashboard and datasets

## ORMØYA



## NORDHAVN

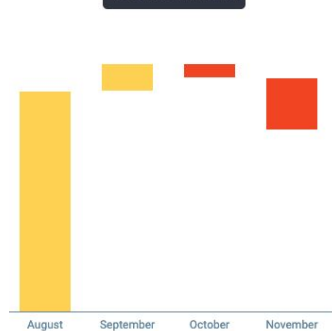

## DOOR ISSUES LAST MONTH

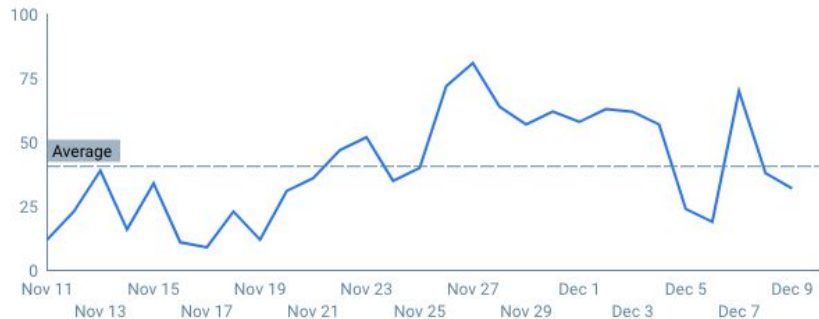

## HARD RESETS ON MAP

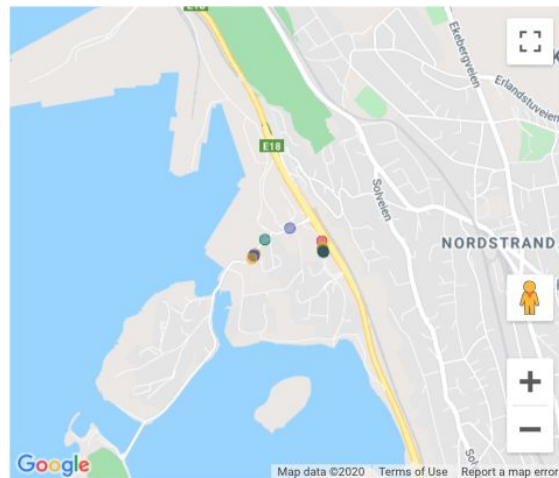

# Agenda

- 1 Introduction to Holo and our ambitions
- 2 Operations overview
- 3 Tools in use
- 4 Future Operations**



# Holo is focused on increasing complexity in different environments with a sustainable business case

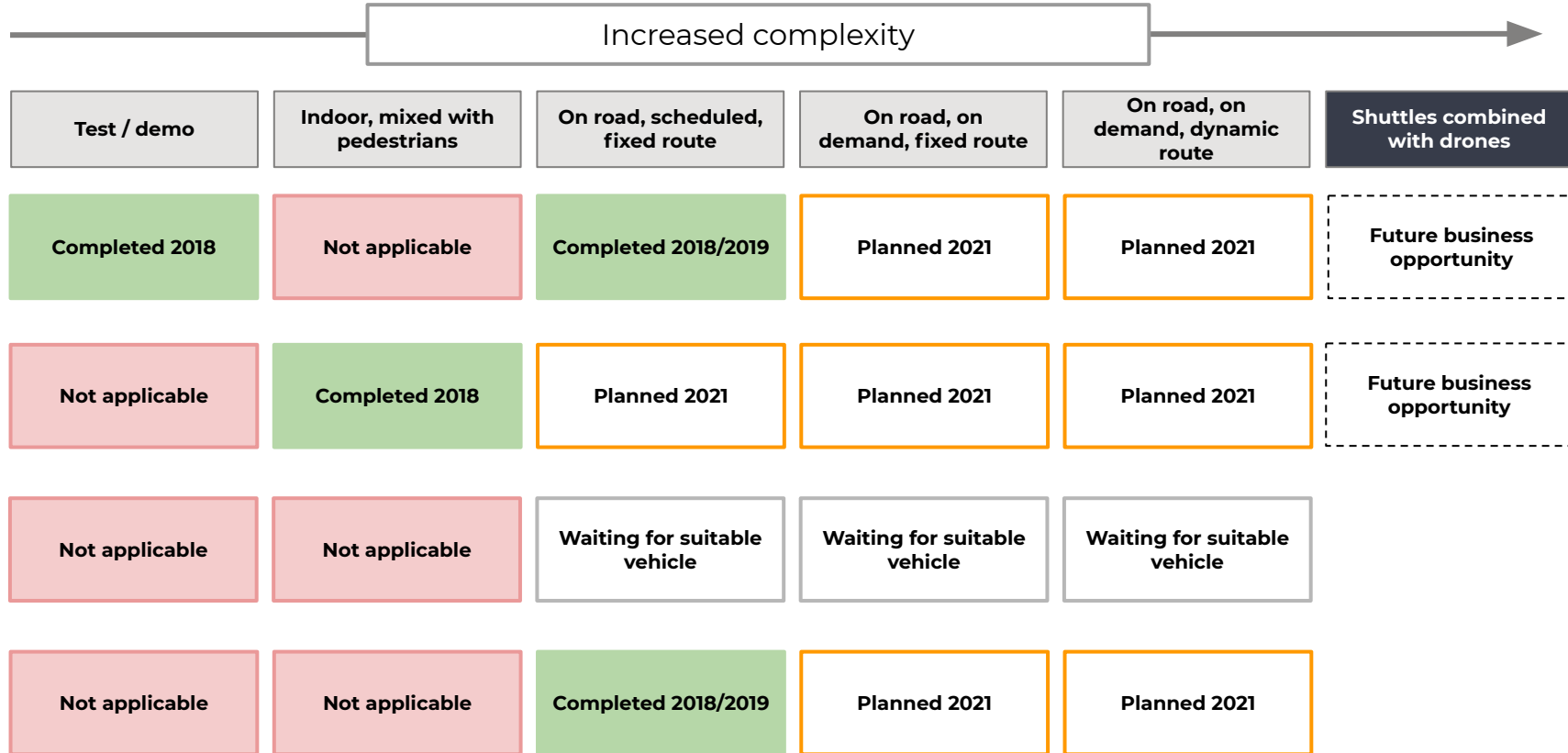

# Questions?

holo

# Looking for new partnerships

Kenneth Jensen  
Head of Operations  
keje@letsholo.com

CPH, December 11th, 2020

- Investment - take an ownership part of Holo and gain insight into our operational experience.
- Provide Holo with a vehicle and accelerate own learnings in real-life scenarios

# Thank you for your attention!

Kenneth Jensen  
Head of Operations  
[keje@letsholo.com](mailto:keje@letsholo.com)

CPH, December 11th, 2020

holo